

SAJ



GUANGZHOU SANJING ELECTRIC CO.,LTD



Tel: (86)20 66608588 Fax: (86)20 66608589 Web: www.saj-electric.com

Add: SAJ Innovation Park, No.9, Lizhishan Road, Science City, Guangzhou High-tech Zone, Guangdong, P.R.China

SAJ

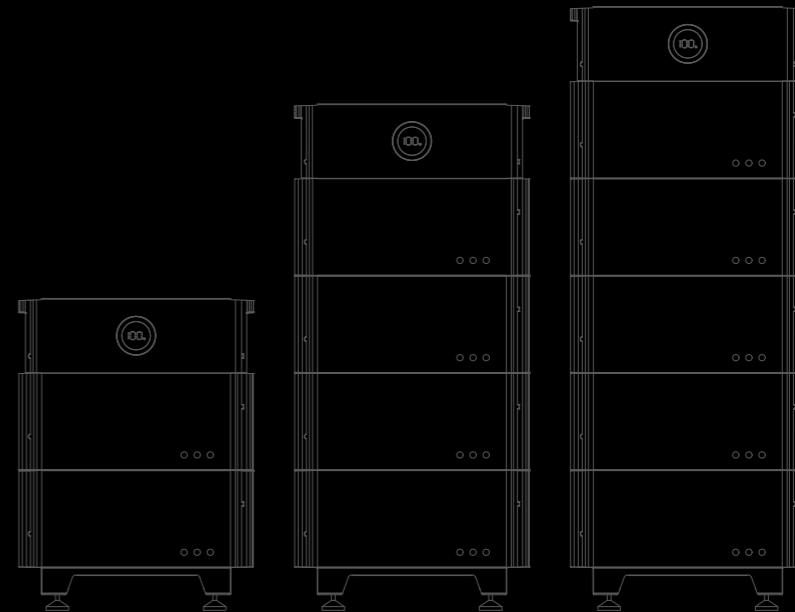

B2 Series

HIGH VOLTAGE BATTERY

USER MANUAL

B2-5.0-25.0-HV1

B2-5.0-25.0-HV5

Preface

Thank you for choosing SAJ battery. We are pleased to provide you first-class products and exceptional service.

This manual includes information for installation, operation, maintenance, trouble shooting and safety. Please follow the instructions of this manual so that we can ensure delivery of our professional guidance and wholehearted service.

Customer-orientation is our forever commitment. We hope this document proves to be of great assistance in your journey for a cleaner, greener world.

Please check for the latest version at www.saj-electric.com

Guangzhou Sanjing Electric Co., Ltd.



TABLE OF CONTENTS

1. SAFETY PRECAUTIONS	1
1.1 Scope of Application	2
1.2 Safety Instructions	2
1.3 Target Group	2
2. PREPARATION	3
2.1 Safety Instructions	4
2.2 Explanations Of Symbols	5
2.3 Battery Handling	6
2.4 Emergency Situation	6
3. PRODUCT INFORMATION	9
3.1 Application Scope of Products	10
3.2 Specification for Product Model	10
3.3 Overview of Products	11
3.4 Battery Terminals Description	11
3.5 Datasheet	13
4. INSTRUCTIONS FOR INSTALLATION	15
4.1 Unpacking and Inspection	16
4.1.1 Checking the Package	16
4.1.2 Scope of Delivery	16
4.2 Installation and Position	17
4.2.1 Installation Position and Clearance	17
4.2.2 Mounting Method	19
4.3 Mounting Procedure	20
4.3.1 Installation Tools	20
4.3.2 Mounting Procedure	21
5. ELECTRICAL CONNECTION	29
5.1 Additional Grounding Cable	30
5.2 Connecting Battery COMM Cable	32
5.3 Connecting Battery Power Cable	33
5.4 Connecting Battery to Inverter	34
5.5 Communication Interface	35
5.6 Installation of Side Covers	36
6. COMMISSIONING	37
6.1 Start Up and Shut Down the Battery	38
6.1.1 Start Up	38
6.1.2 Shut Down	38
6.2 Introduction of Human-computer Interface	39
6.3 Commissioning	40
7. Battery Maintenance	41
7.1 Transportation	42
7.2 Storage	42
7.3 Maintenance	43
8. Troubleshooting and Warranty	45

1.1 Scope of Application

This User Manual describes instructions and detailed procedures for installing, operating, maintaining, and troubleshooting of the following SAJ products:

B2-5.0-HV1; B2-10.0-HV1; B2-15.0-HV1; B2-20.0-HV1; B2-25.0-HV1;

B2-5.0-HV5; B2-10.0-HV5; B2-15.0-HV5; B2-20.0-HV5; B2-25.0-HV5;

1.2 Safety Instructions



DANGER

· DANGER indicates a hazardous situation which, if not avoided, will result in death or serious injury.



WARNING

· WARNING indicates a hazardous situation which, if not avoided, can result in death or serious injury or moderate injury.

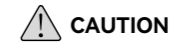

CAUTION

· CAUTION indicates a hazardous condition which, if not avoided, can result in minor or moderate injury.

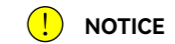

NOTICE

· NOTICE indicates a situation that can result in potential damage, if not avoided.

1.3 Target Group

Only qualified electricians who have read and fully understood all safety regulations contained in this manual can install, maintain and repair the battery. Operators must be aware of the high-voltage device.

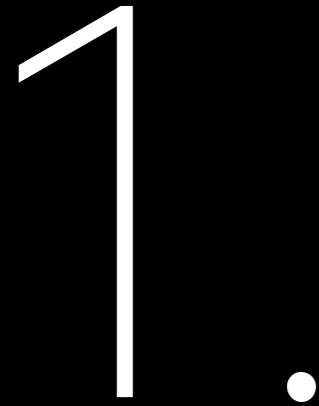

SAFETY PRECAUTIONS



2.

PREPARATION



2.1 Safety Instructions

For safety, be sure to read all the safety instructions carefully prior to any works, and please observe the appropriate rules and regulations of the country or region where you installed B2 battery.

DANGER

- Please keep the power off prior to any operations
- Do not use the battery or the battery control unit if it is defective, broken or damaged.
- Do not expose the battery to temperatures in excess of 50°C.
- Do not subject the battery to any strong force.
- Do not place the battery near a heat source, such as direct sunlight, a fireplace.
- Keep inflammable and explosive dangerous items or flames away from the battery.
- Do not soak the battery in water or expose it to moisture or liquids.
- Do not use the battery in vehicles.
- Do not use the battery in areas where the ammonia content of the air exceeds 20ppm.

WARNING

- Only qualified personnel who has full knowledge of local safety regulations and local standards on battery can install, maintain, retrieve and process this product.
- SAJ electric shall not be liable for any loss or warranty claims arising from any unauthorized change of product which may cause fatal injury to the operator, third party or equipment performance.
- For personal and property safety, do not short-circuit the positive (+) and negative (-) electrode terminals.









CAUTION

- Do not modify or change any components in the battery.
- Risk of damage due to improper modification
- Use professional tools when operating the products.

NOTICE

- During installation of the battery B2 high voltage battery, circuit breaker must be disconnected from the battery pack wiring.
- The battery B2 can only be used as a set with SAJ's H2 high voltage series storage inverter, otherwise it cannot be used normally.

2.2 Explanations of Symbols

Symbol	Description
	Dangerous electrical voltage This device is directly connected to public grid, thus all work to the battery shall only be carried out by qualified personnel.
	No open flames Do not place or install near flammable or explosive materials.
	Danger of hot surface The components inside the battery will release a lot of heat during operation. Do not touch metal plate housing during operating.
	Attention Install the product out of reach of children
	An error has occurred Please go to Chapter 7 "Troubleshooting" to remedy the error.
	This device shall NOT be disposed of in residential waste
	This battery module shall NOT be disposed of in residential waste
	CE Mark Equipment with the CE mark fulfills the basic requirements of the Guideline Governing Low-Voltage and Electro-magnetic Compatibility.
	Recyclable

2.3 Battery Handling

Operate and use the battery properly according to user manual, any attempt to modify battery without the permission from SAJ will void the limit warranty for the battery.

- The battery must be installed at a suitable location with sufficient ventilation
- Do not use the battery if it is defective, damaged or broken.
- Only use the battery with compatible inverter.
- Do not use the battery with other type of battery.
- Make sure the battery is grounded prior to use.
- Do not pull out any cables or open the battery enclosure when the battery is powered on.
- Only use the battery as intended and designed.

2.4 Emergency Situation

Despite of its careful and professional protection design against any hazards, damage of the battery may still possible. If a small amount of battery electrolyte is released due to a serious damage of the outer casing; or if the battery explodes due to not being treated timely after a fire breaks out nearby, and leaks out poisonous gases such as carbon monoxide, carbon dioxide and etc., the following actions are recommended:

- 1) Eye contact: Rinse eyes with a large amount of running water and seek medical advice
- 2) Contact with skin: Wash the contacted area with soap thoroughly and seek medical advice
- 3) Inhalation: If you feel discomfort, dizziness or vomiting, seek medical advice immediately.
- 4) Use a FM-200 or Carbon Dioxide (CO₂) fire extinguishers to extinguish the fire if there is a fire in the area where the battery pack is installed. Wear a gas mask and avoid inhaling toxic gases and harmful substances produced by the fire.
- 5) Use an ABC fire extinguisher, if the fire is not caused by battery and not spread to it yet.

⚠ WARNING

- If a fire has just occurred, try to disconnect the battery circuit breaker and cut off the power supply first, but only if you can do so without endangering yourself.
- If the battery is on fire, do not attempt to extinguish the fire but evacuate the crowd immediately.

Potential danger of damaged battery:

Chemical Hazard: Despite of its careful and professional protection design against any hazard results, rupture of battery may still occur due to mechanical damage, internal pressure etc., and may result in a leakage of battery electrolyte. The electrolyte is corrosive and flammable. When there is fire, the toxic gases produced will cause skin and eyes irritation, and discomfort after inhalation. Therefore:

- 1) Do not open damaged batteries;
- 2) Do not damage the battery again (shock, fall, trample, etc.);
- 3) Keep damaged batteries away from water (except to prevent an energy storage system from catching fire);
- 4) Do not expose the damaged battery to the sun to prevent internal heating of the battery.

Electrical hazard: The reason of fire and explosion accidents in lithium batteries is battery explosion. Here are the main factors of battery explosion:

- 1) Short circuit of battery. Short circuit will generate high heat inside battery, resulting in partial electrolyte gasification, which will stretch the battery shell. The temperature reaching ignition point of internal material will lead to explosive combustion.
- 2) Overcharge of battery. Overcharge of battery may precipitate lithium metal. If the shell is broken, it will come into direct contact with the air, resulting in combustion. The electrolyte will be ignited at the same time, resulting in strong flame, rapid expansion of gas and explosion.

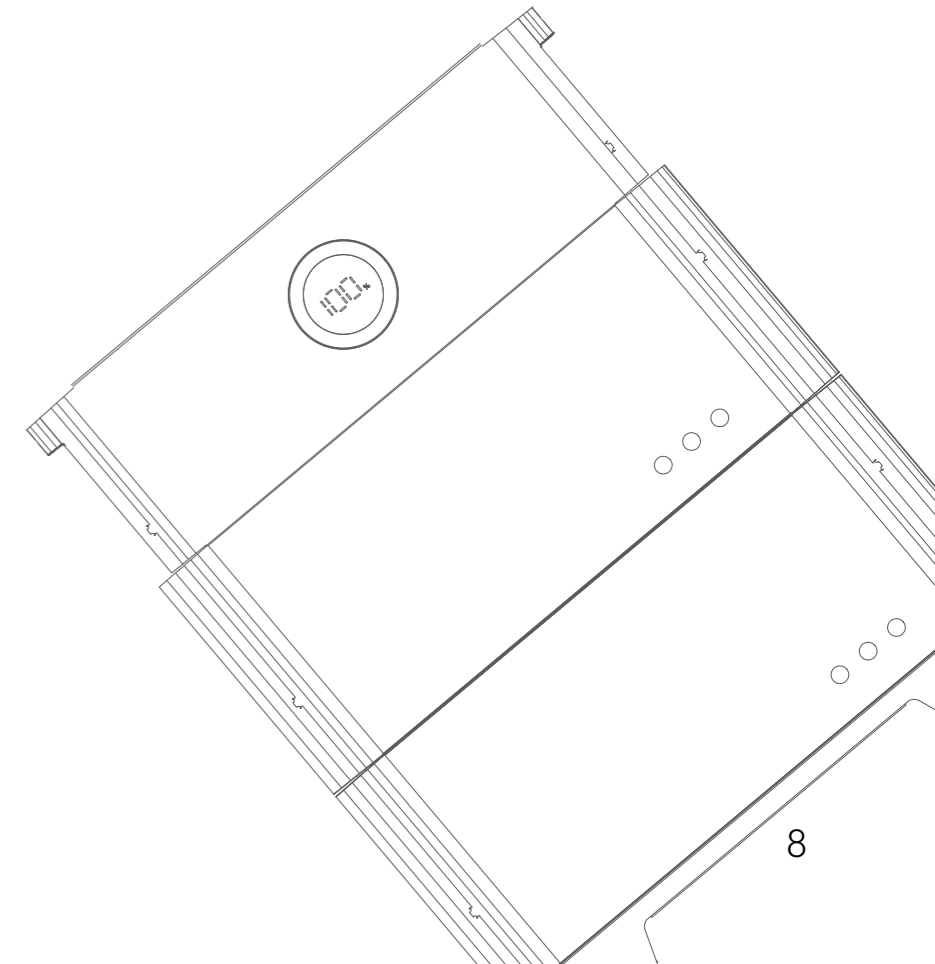

3.

PRODUCT INFORMATION



3.1 Application Scope of Products

The battery B2 is applied to residential photovoltaic storage system. The battery is built internally with a battery management system (BMS), which is used to ensure efficiency of the battery and protect the battery from operating outside its specified limitations. B2 battery is a high voltage battery system. The battery employs modular design for easy installation and wiring.

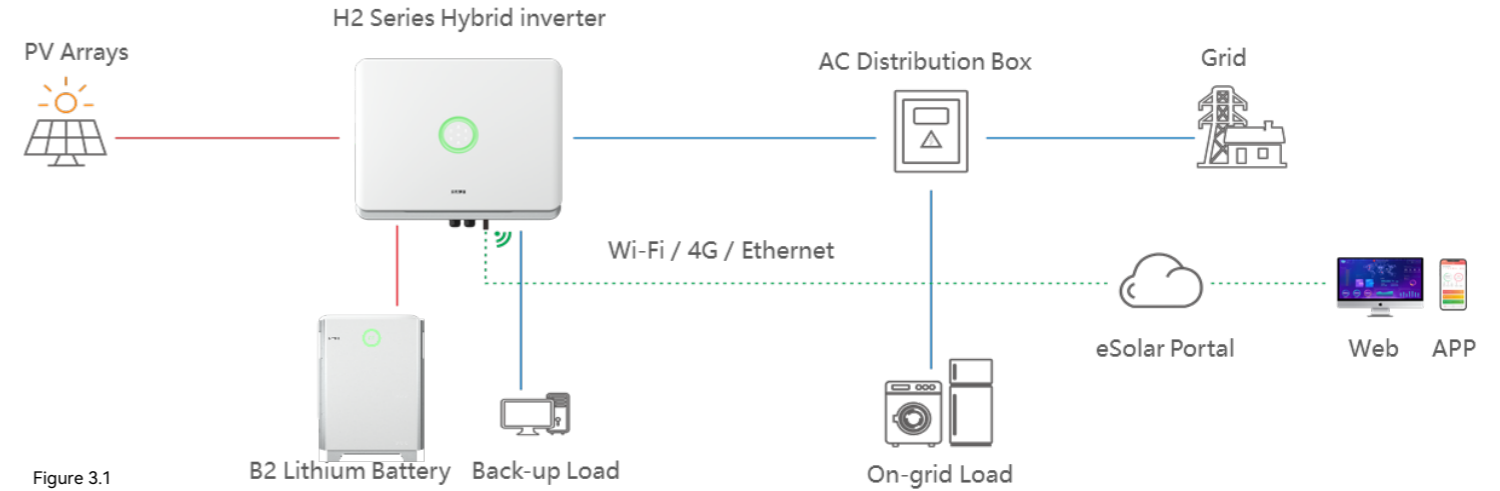

Figure 3.1
B2 battery application

3.2 Specification for Product Model

B2 - X.X - HV1/5
① ② ③

- ① B2 represents for product name.
- ② X.X represents rated energy XkWh of battery, for example, 5.0 means 5.0kWh.
- ③ HV means high voltage

3.3 Overview of Products

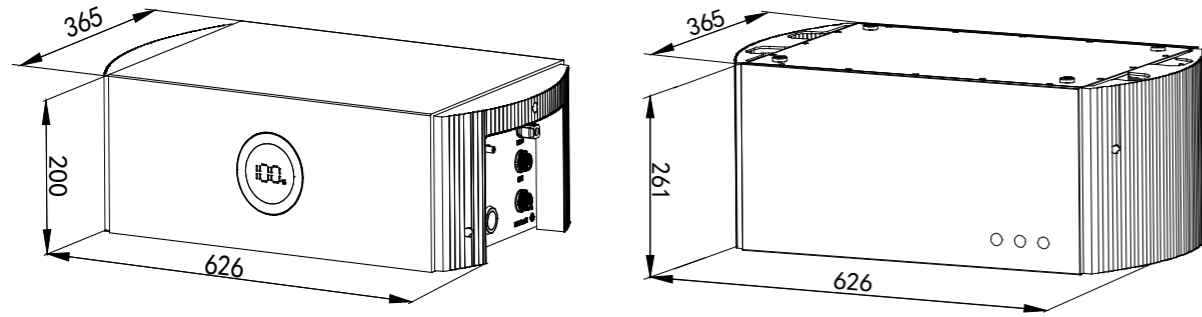

Figure 3.2
Dimensions of battery control unit and battery module

3.4 Battery Terminals Description

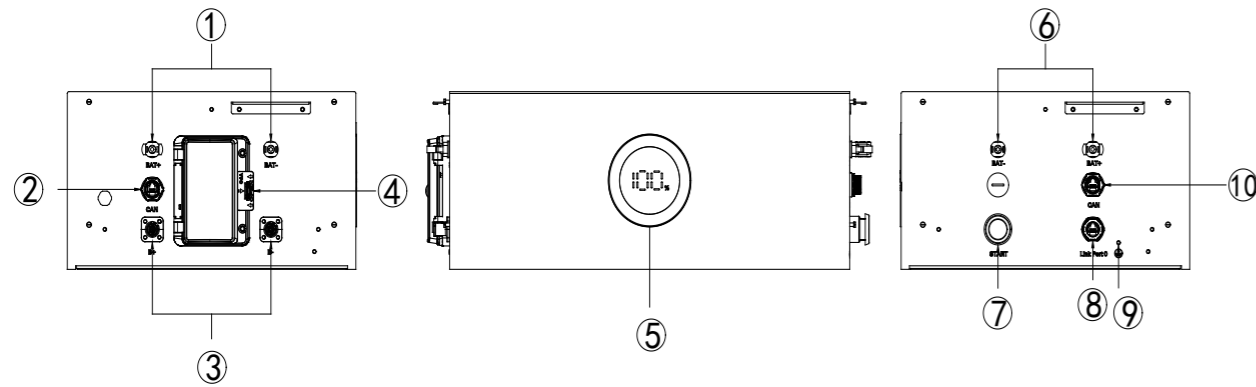

Figure 3.3 Battery control unit interface (left view and right view)

Position	Name
1	BAT +/BAT- port (to inverter)
2	Communication port (to inverter)

3	B+/B- port (to battery module)
4	Circuit breaker
5	Display
6	BAT+- port (for parallel connection)
7	Start button
8	Communication port (to battery module)
9	Ground
10	Communication port (for parallel connection)

Table 3.1 Battery control unit interface

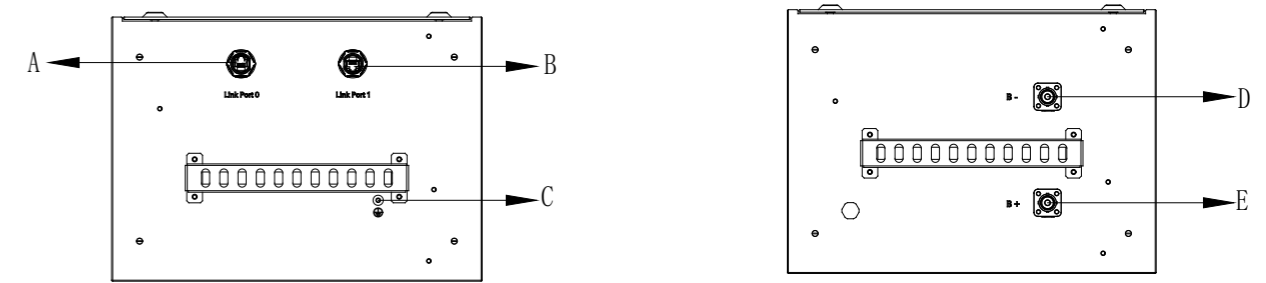

Figure 3.4 Battery module interface (left view & right view)

Code	Name
A	Link Port 0
B	Link port 1
C	Ground
D	B - port
E	B +port

Table 3.2 Battery module interface

3.5 Datasheet

Model	B2-5.0-HV1	B2-10.0-HV1	B2-15.0-HV1	B2-20.0-HV1	B2-25.0-HV1
Battery Module	BU2-5.0-HV1 (1P32S 102.4V50Ah)				
No. of Modules	1	2	3	4	5
Rated Energy [kWh]	5.0	10.0	15.0	20.0	25.0
Usable Energy [kWh]	4.5	9.0	13.5	18.0	22.5
Dimension (H*W*D)[mm]	261*626*365	522*626*365	783*626*365	1044*626*365	1305*626*365
Weight [kg]	50.5	101	151.5	202	252.5
Nominal Voltage [V]	102.4	204.8	307.2	409.6	512
Operating Voltage [V]	89.6 ~ 115.2	179.2 ~ 230.4	268.8 ~ 345.6	358.4 ~ 460.8	448 ~ 576.0
Max. Charge Current [A]	30				
Max. Discharge Current [A]	30				
Rated Capacity [Ah]	50				
Battery Designation	IFpP42/149/103[(1P32S)nS]E/-10+40/90, n=number of modules				
Control Module	BC2-HV1				
Dimension (H*W*D)[mm]	200*626*365				
Weight [kg]	11				
General Data					
Ingress Protection	IP65				
Dimension (H*W*D)[mm] (Battery Control Unit + Battery Unit)	461*626*365	722*626*365	983*626*365	1244*626*365	1505*626*365
Weight [kg] (Battery Control Unit + Battery Unit)	61.5	112	162.5	213	263.5
Mounting	Wall-Mounted / Ground-Mounted				
Operating Temperature Range	Charging: 0 ~ 50°C; Discharging: -10 ~ 50°C				
Ambient Humidity	0 ~ 95% non-condensing				
Cooling Method	Natural convection				
Communication	CAN				
Warranty [Year]	Refer to the warranty card.				
Applicable Standard	IEC62619(Cell&Pack)/EN62477-1/EN61000-6-1/2/3/4/UN38.3				

Model	B2-5.0-HV5	B2-10.0-HV5	B2-15.0-HV5	B2-20.0-HV5	B2-25.0-HV5
Battery Module	BU2-5.0-HV5 (1P32S 102.4V50Ah)				
No. of Modules	1	2	3	4	5
Rated Energy [kWh]	5.0	10.0	15.0	20.0	25.0
Usable Energy [kWh]	4.5	9.0	13.5	18.0	22.5
Dimension (H*W*D)[mm]	261*626*365	522*626*365	783*626*365	1044*626*365	1305*626*365
Weight [kg]	52.5	105	157.5	210	262.5
Nominal Voltage [V]	102.4	204.8	307.2	409.6	512
Operating Voltage [V]	89.6 ~ 115.2	179.2 ~ 230.4	268.8 ~ 345.6	358.4 ~ 460.8	448 ~ 576.0
Max. Charge Current [A]	30				
Max. Discharge Current [A]	30				
Rated capacity [Ah]	50				
Battery designation	IFpP42/149/103[(1P32S)nS]E/-10+40/90, n=number of modules				
Control Module	BC2-HV1				
Dimension (H*W*D)[mm]	200*626*365				
Weight [kg]	11				
General Data					
Ingress Protection	IP65				
Dimension (H*W*D)[mm] (Battery Control Unit + Battery Unit)	461*626*365	722*626*365	983*626*365	1244*626*365	1505*626*365
Weight [kg] (Battery Control Unit + Battery Unit)	63.5	116	168.5	221	273.5
Mounting	Wall-Mounted / Ground-Mounted				
Operating Temperature Range	Charging: 0 ~ 50°C; Discharging: -10 ~ 50°C				
Ambient Humidity	0 ~ 95% non-condensing				
Cooling Method	Natural convection				
Communication	CAN				
Warranty [Year]	Refer to the warranty card.				
Applicable Standard	IEC62619(Cell&Pack)/EN62477-1/EN61000-6-1/2/3/4/UN38.3				

4.

INSTRUCTIONS FOR INSTALLATION



4.1 Unpacking and Inspection

4.1.1 Checking the Package

Although SAJ's battery have thoroughly tested and checked before delivery, it is uncertain that the battery may suffer damages during transportation. Please check the package for any obvious signs of damage, and if such evidence is present, do not open the package and contact your dealer as soon as possible

4.1.2 Scope of Delivery

Please contact after sales if there are missing or damaged components.

Battery Control Unit Package

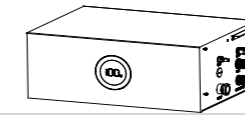

Battery control unit*1

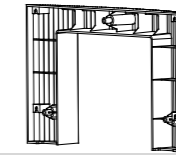

Side cover*2



Documents



Grounding cable*1



M4*25 screw*6



M10*80 screw*2

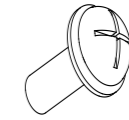

M6*12 screw*2



M4*10 screw*1



Communication cable*1



Power cable (1450mm)*1
Power cable (650mm)*1



Power cable (150mm)*1



Battery cable*2 (Battery control unit to inverter)

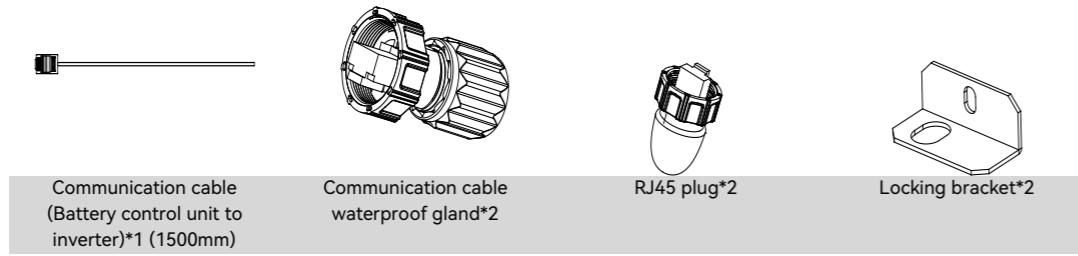
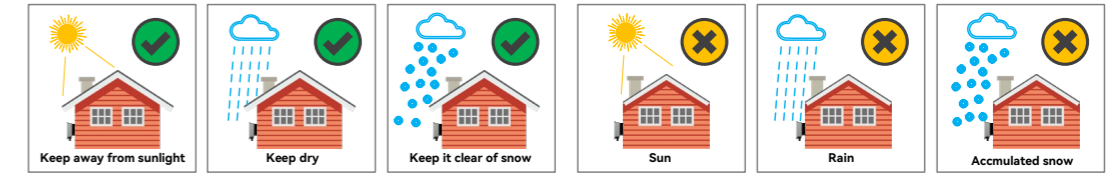
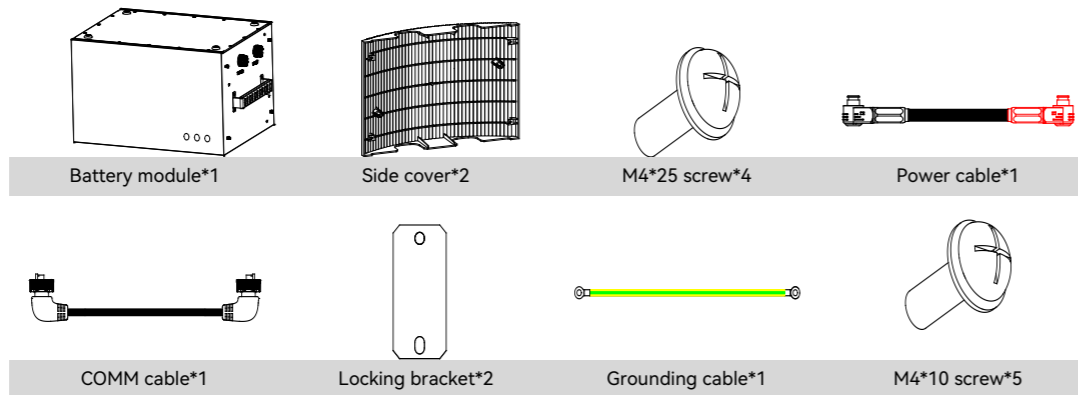

Figure 4.1 Installation location



The documents include the user manual and packaging list.

Battery Module Package



Please reserve enough clearance around the battery to ensure a good air circulation at the installation area. Because poor air ventilation will affect the working performance of internal electronic components and shorten the service life of the system.

4.2 Installation Method and Position

4.2.1 Installation Position and Clearance

This device is cooled by natural convection and suggested an indoor installation or an installation under a sheltered place to prevent the battery from exposure to direct sunlight, rain and snow erosion.

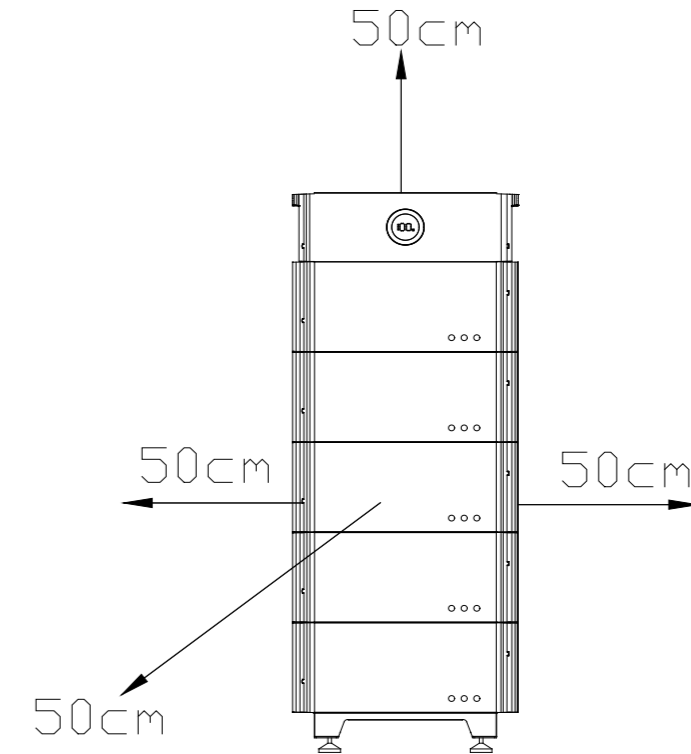

Figure 4.2 Installation clearance

4.2.2 Mounting Method

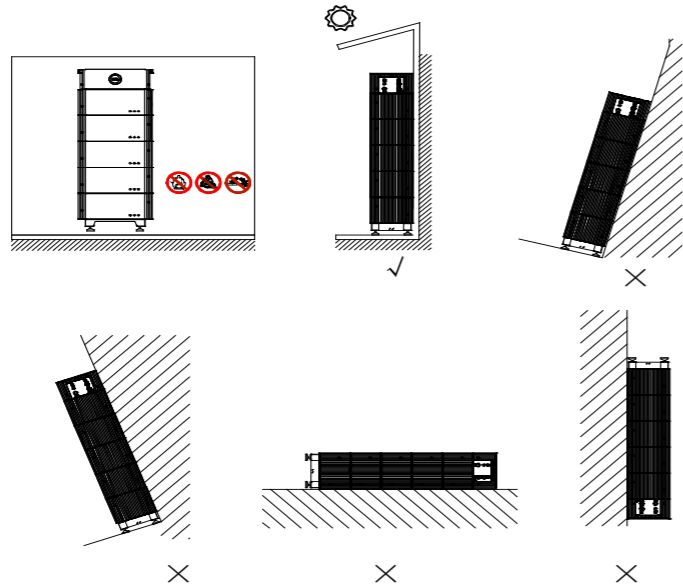

Figure 4.3
Mounting method

- ① The equipment employs natural convection cooling, and it can be installed indoor or outdoor.
- ② Mount vertically. Never install the battery tilted forwards, sideways, horizontally or upside down.
- ③ When mounting the battery, please consider the solidity of wall for battery, including accessories, make sure the wall has enough strength to hold the screws and bear the weight of products. Please ensure the mounting bracket mounted tightly.

Installation Environment Requirements

- The installation environment must be free of inflammable or explosive materials.
- Install the battery away from heat source.
- Do not install the battery at a place where the temperature changes extremely.
- Keep the battery away from children.

Note: When installing outdoors, the height of the battery from the ground should be considered to prevent the battery from soaking in water. The specific height is determined by the site environment.

4.3 Mounting Procedure

4.3.1 Installation Tools

Installation tools include but are not limited to the following recommended ones. Please use other auxiliary tools on site if necessary.

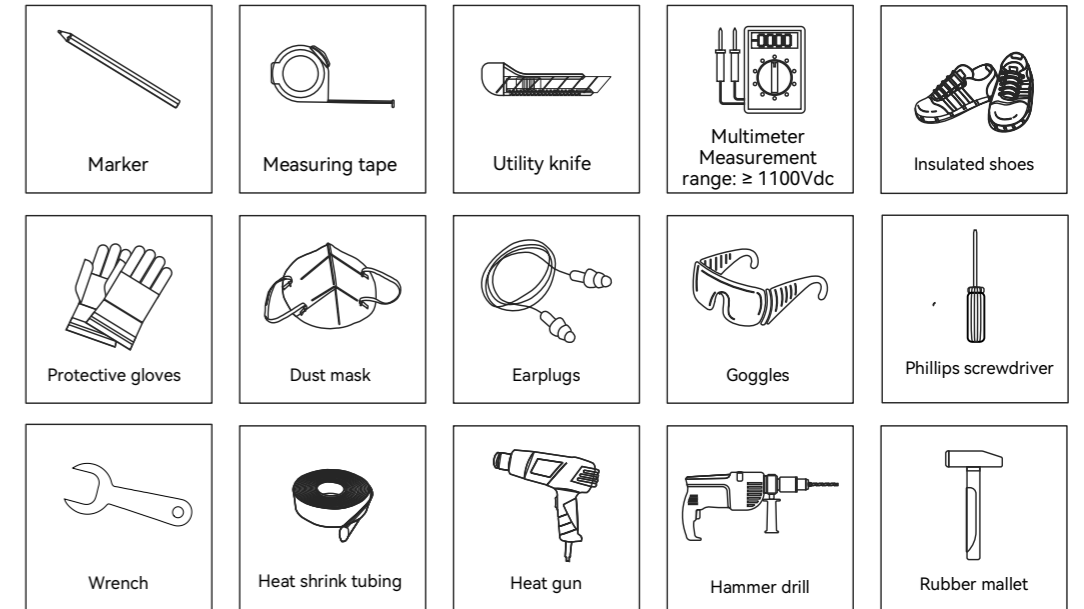

4.3.2 Mounting Procedures

The battery employs either ground mounting or wall mounting and its position is determined by the drilled holes of bracket.

Ground Mounting

The ground should be flat and no inclination.

Step 1: Assemble the base. Adjust the height of foot cup, make sure the surface of base is horizontal.

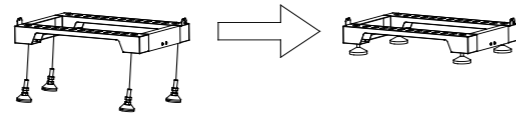

Figure 4.4
Assembling the base

Step 2: Place the base on the ground, make sure the edge of base is 27mm away from wall. Place the battery module on the base and secure it with screws (M4*10).

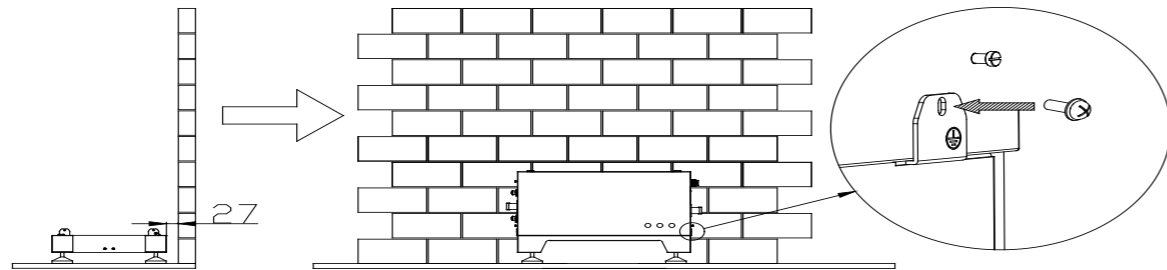

Figure 4.5
Securing the battery

Step 3: Stack the rest of the battery modules up and secure the battery modules with locking brackets by screws (M4*10)

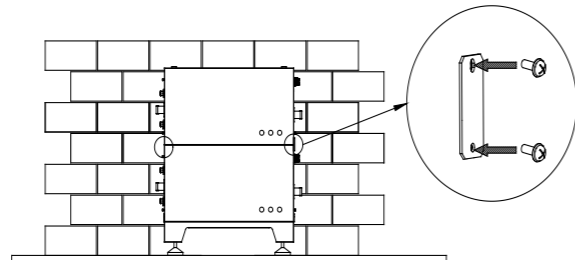

Figure 4.6
Securing battery modules with locking brackets

Step 4: After the battery modules installation, mark the proper positions of battery control unit and drill holes (13mm in diameter, 65mm in depth) on those positions by using the battery control unit as a template. Remove the rubber feet for the top battery module before installing battery control unit.

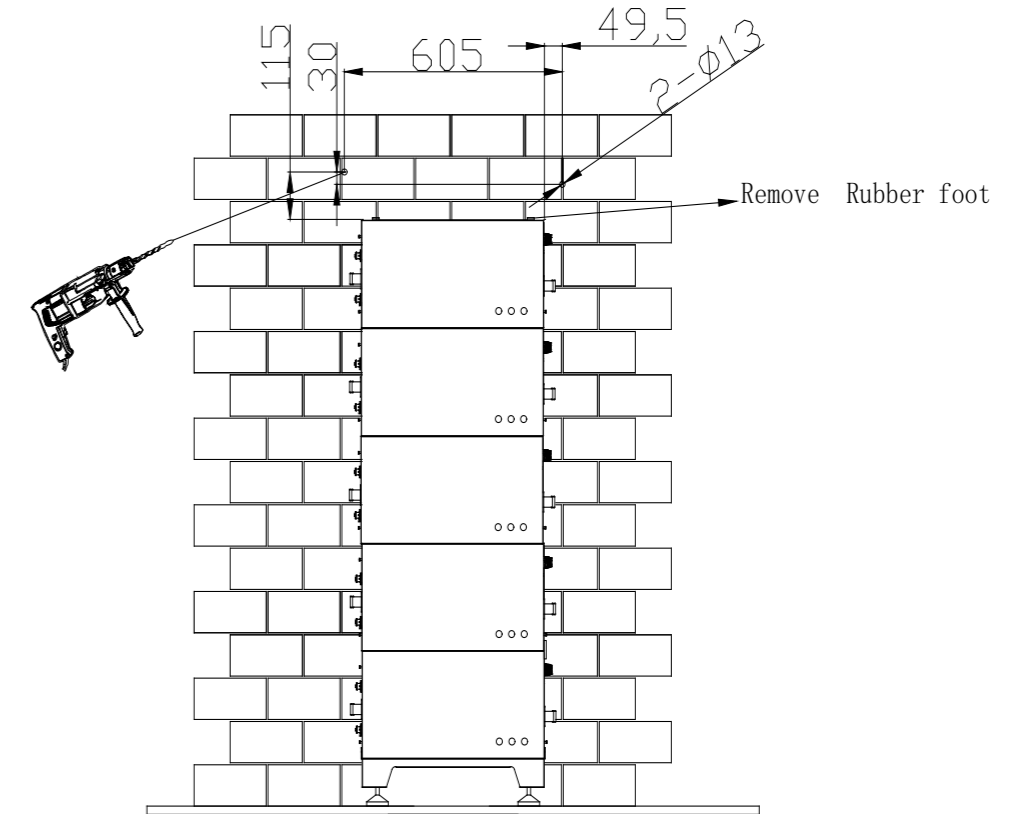

Figure 4.7
Drilling holes to install battery control unit

Step 5: Use a rubber hammer to drive the screw fixing seat into the holes to fix the bracket, use the wrench to tighten the screws (M10*80 screw) to secure the battery control unit. Secure the locking bracket and battery control unit with a screw (M6*12).

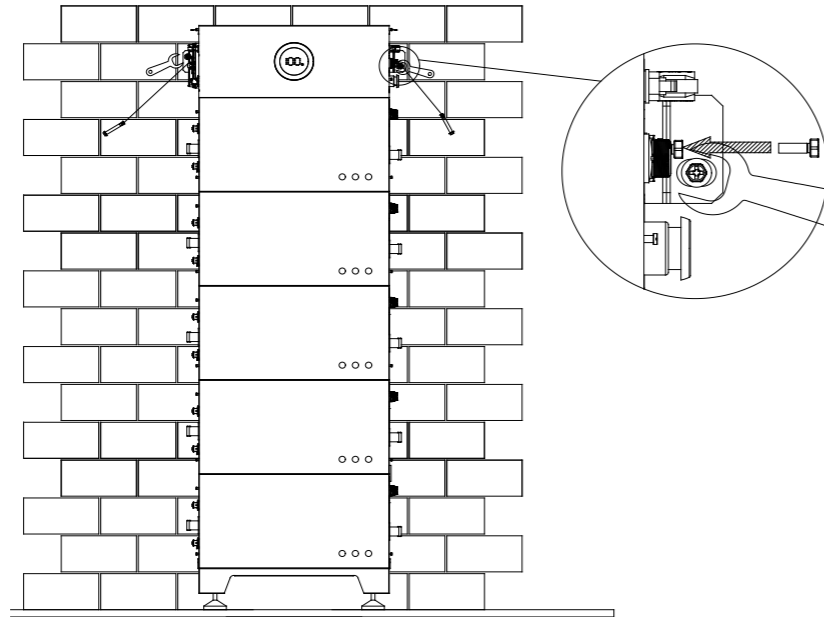

Figure 4.8
Installing battery control unit

Wall Mounting

Make sure that the wall is capable of mounting screws and supporting the weight of the battery pack before installation. For safety reason, solid wall is recommended for wall mounting, cavity wall and timber wall are not allowed to install the battery system.

Step 1: Assemble the bracket and secure it with screws

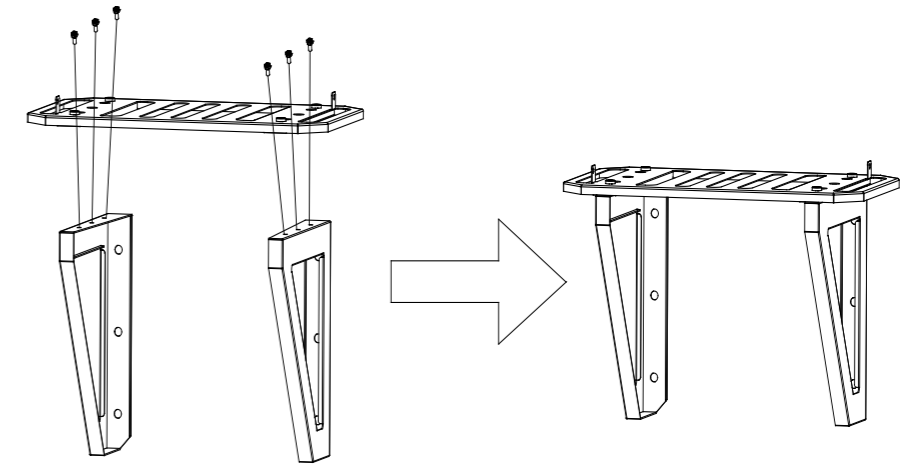

Figure 4.9
Assembling the bracket

Step 2: Mark the proper positions of mounting bracket and drill holes on those positions (13mm in diameter, 65mm in depth) by using the mounting bracket as a template, and then use a rubber hammer to drive the screw fixing seat into the holes to fix the bracket.

Note: It is recommended to leave no gap between the bracket and ground.

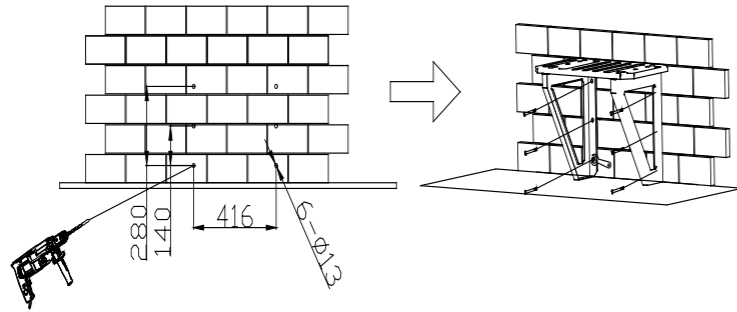

Figure 4.10
Drill holes' dimensions of
bracket

Step 3: Install the battery module on the bracket, make sure the battery module position fits with the position of rubber feet on bracket, and use a screw(M4*10) to secure it with locking brackets.

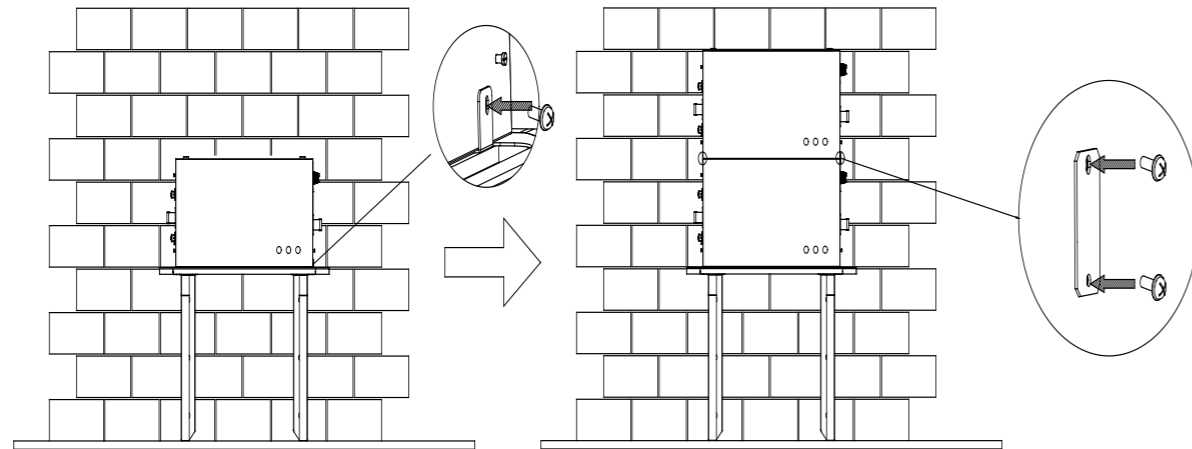

Figure 4.11
Install the locking bracket

Step 4: After the battery modules installation, mark the proper positions of mounting bracket and drill holes (13mm in diameter, 65mm in depth) on those positions by using the mounting bracket as a template. Remove the rubber feet for the top battery module before installing battery control unit.

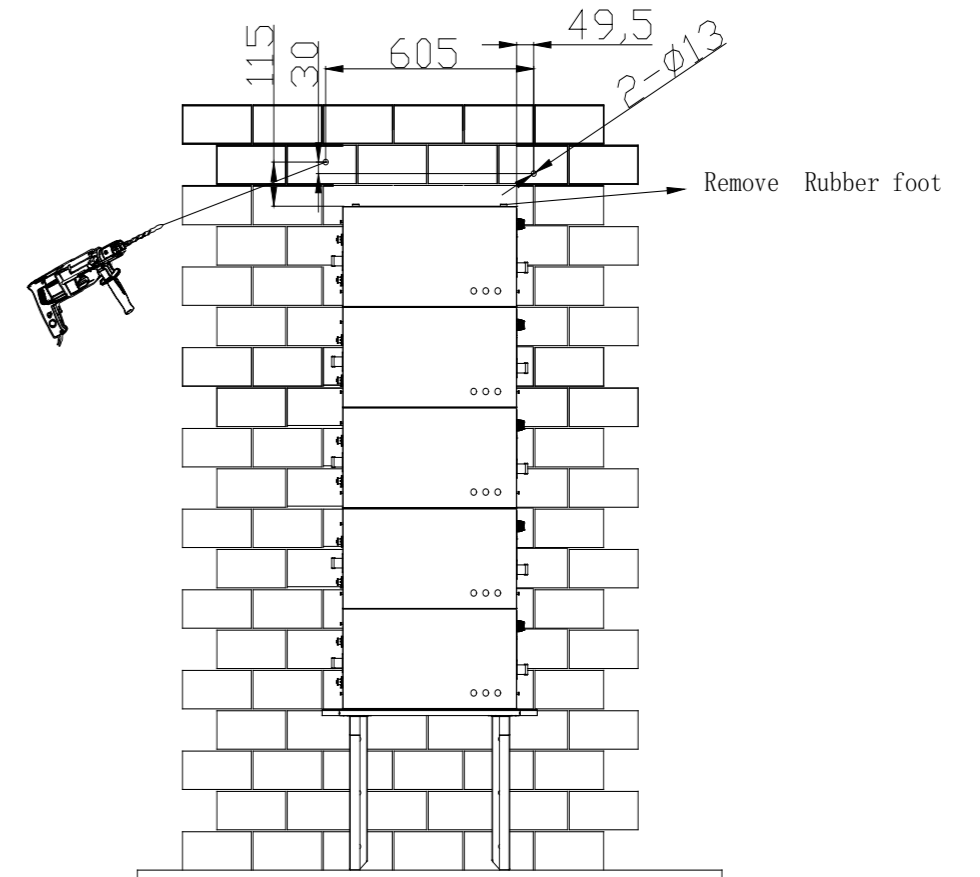

Figure 4.12
Drilling holes for installation of
battery control unit

Step 5: Use a rubber hammer to drive the screw fixing seat into the holes to fix the bracket, use the wrench to tighten the screws (M10*80 screw) to secure the battery control unit, secure the locking bracket and battery control unit with a screw (M6*12).

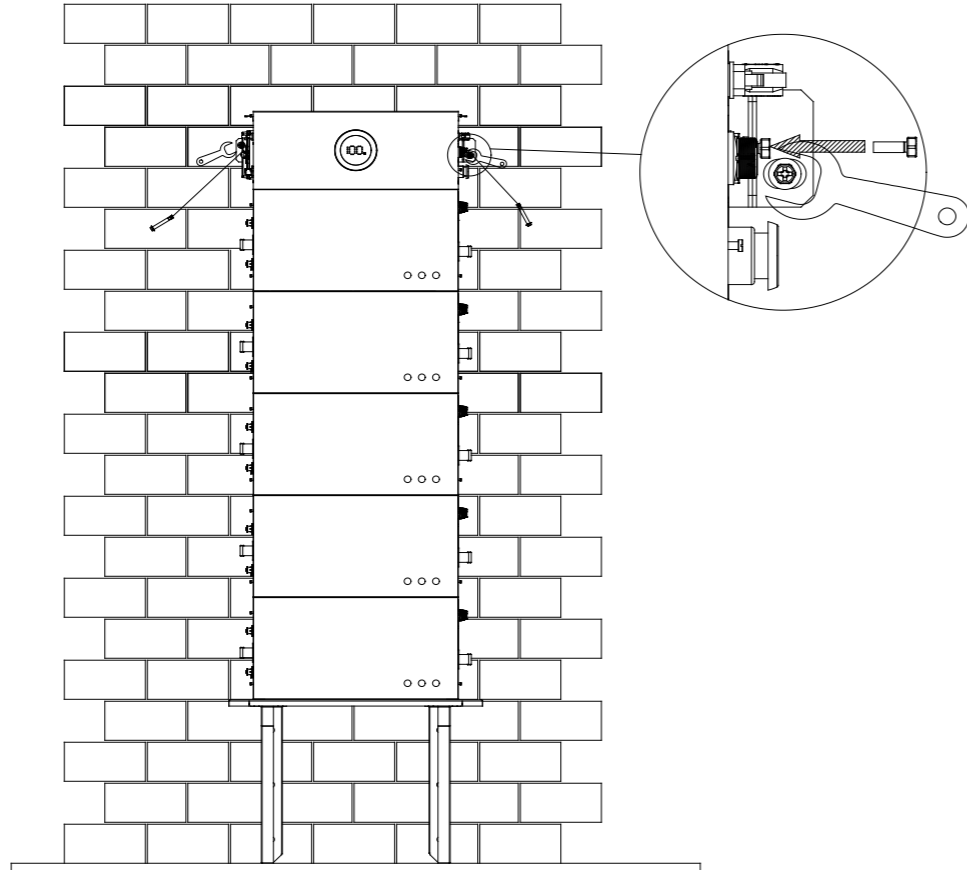
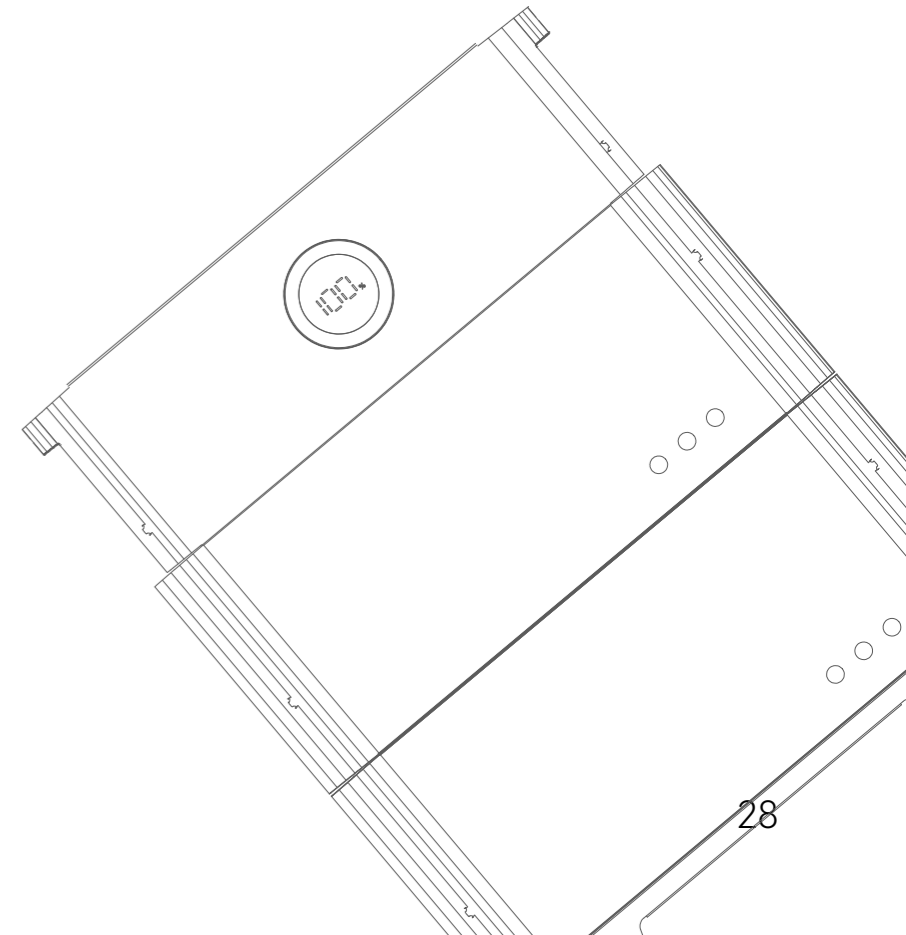

Figure 4.13
Installing battery control unit



5.

ELECTRICAL CONNECTION



5.1 Additional Grounding Cable

Electrical connection must only be operated by professional technicians. Before connection, necessary protective equipment must be employed by technicians, including insulating gloves, insulating shoes and safety helmet.

 WARNING
· Connect this additional grounding cable before other electrical connection.

Note: The additional cable and OT/DT terminal should be prepared by user themselves.

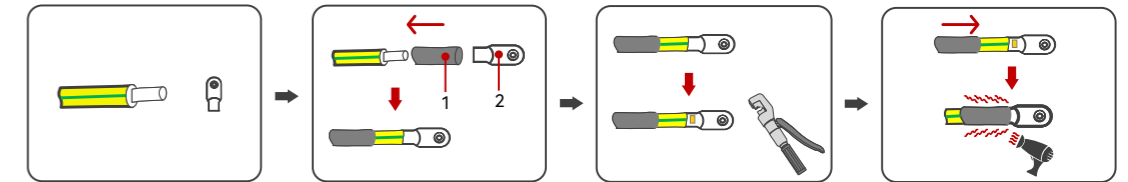

Figure 5.1
Preparing additional grounding cable

1. Heat shrink tubing 2. OT/DT terminal

Remove the screw of grounding terminal and secure the additional grounding cable by insert a screw into the screw hole in the OT/DT terminal. Connect the grounding cables as the following diagram.

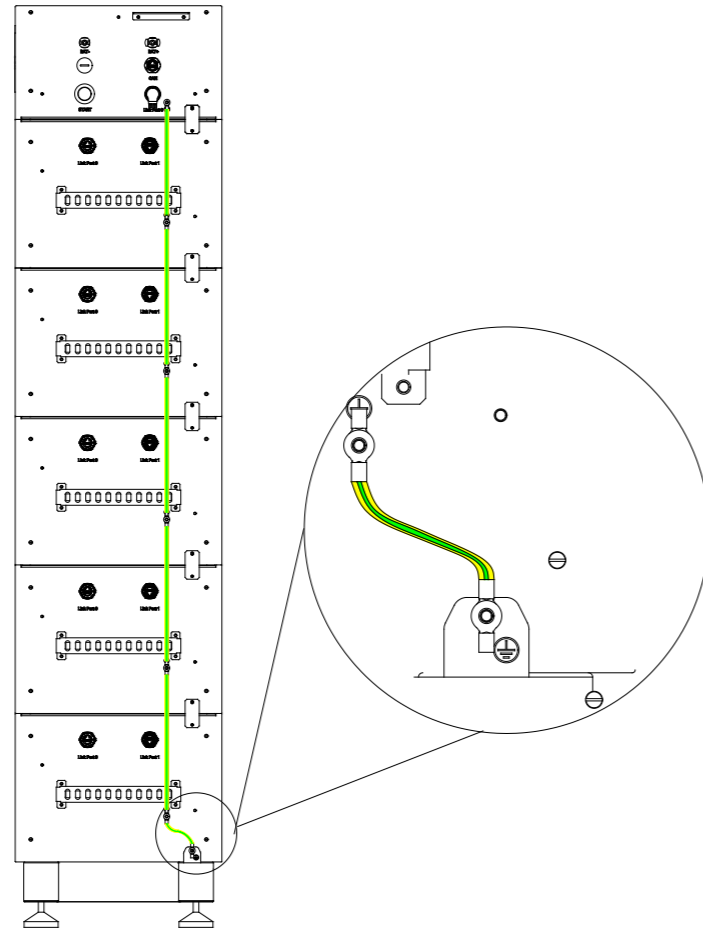

Figure 5.2
Connecting the additional
grounding cable

5.2 Connecting Battery COMM Cable

Step1: Connect link port 0 of battery control unit to link port 1 of battery 5 (the battery number can be varied, it should be depended on the number of battery modules in the system)
Step 2: Repeat step 1 to connect the rest of the battery modules
Step 3: Insert a RJ45 plug to link port 0 of battery 1, insert a RJ45 plug to CAN port of battery control unit
Note: If the RJ45 plug is not installed, a communication error will occur.

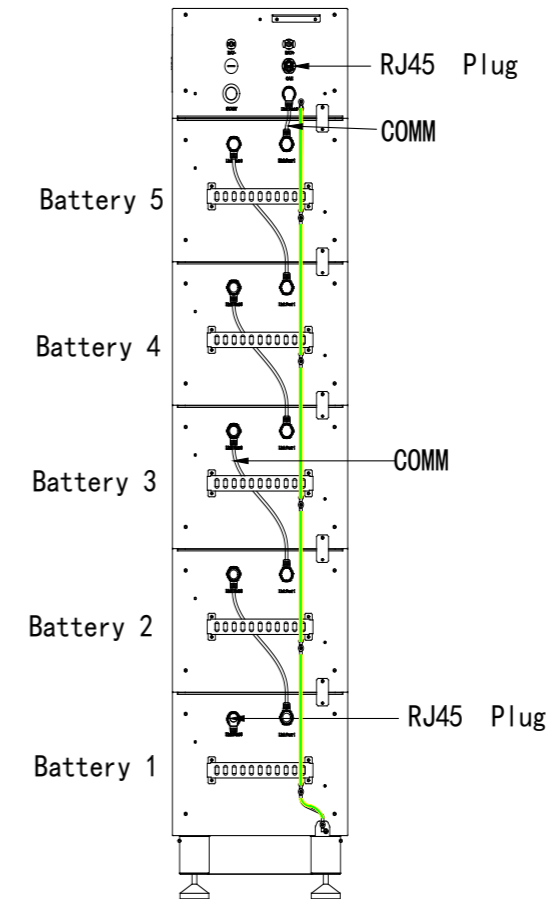

Figure 5.3
Connecting battery COMM cable

5.3 Connecting Battery Power Cable

⚠ WARNING

- Power off the battery system before connecting the power cable to avoid high voltage danger
- The electrical connection of high voltage battery systems must be operated by qualified technicians in accordance with local and national power grid standards and regulations.

Step 1: Connect the power cable from B- port of battery control unit to B- port of the battery 5 (the battery number can be varied, it should be depended on the number of battery modules in the system).

Step 2: Connect power cable from B+ port of battery 5 to B- port of battery 4.

Step 3: Repeat step 2 to connect the rest of the battery modules.

Step 4: Connect the B+ from battery control unit to B+ of battery 1.

Note: Please follow the following diagrams to connect cables.

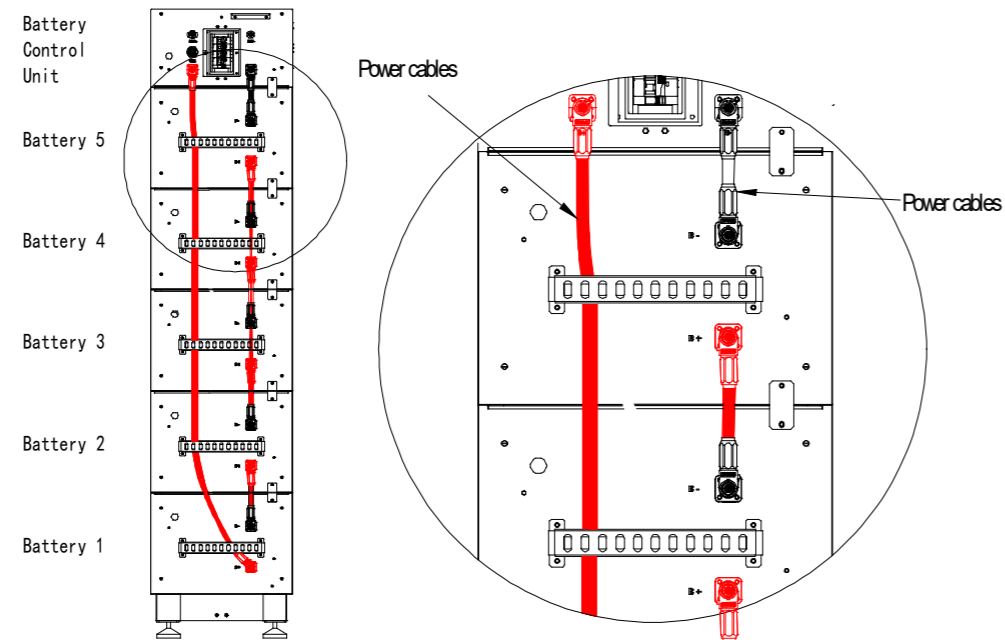

Figure 5.4
Connecting battery power cables

5.4 Connecting Battery to Inverter

Please follow the following diagram to connect battery and inverter.

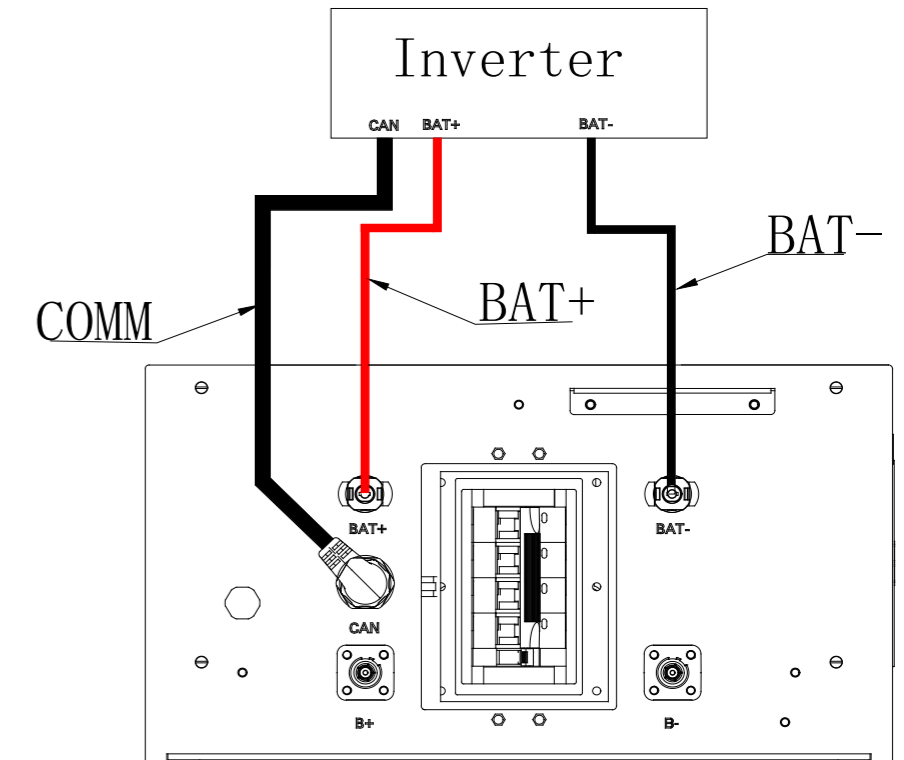

Figure 5.5
Connecting battery system to inverter

5.5 Communication Interface

Note: 1) The communication cable is one end crimped, this crimped end is for battery side connection. The other end is for inverter side connection. Customer should crimp the other end of communication cable by themselves.

- 2) The pinout of RJ45 is detailed in Table 5.1 below.
- 3) Confirm that the DC switch is OFF during installation to avoid short circuit caused by wrong operation during battery wiring.
- 4) Please use the battery cable in original package.

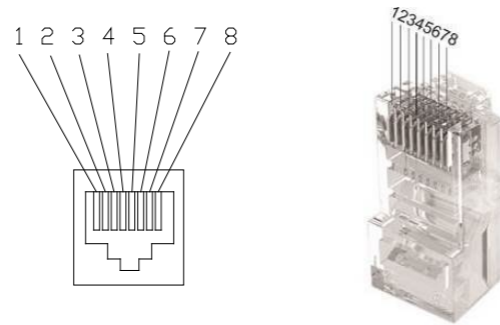

Figure 5.6
Pinout of RJ45

	Color	Name
1	White-orange	Blank
2	Orange	Blank
3	White-green	Blank
4	Blue	CAN-H
5	White-blue	CAN-L
6	Green	Blank
7	White-brown	RS485-A
8	Brown	RS485-B

Table 5.1
Pinout of RJ45
Description

5.6 Installation of Side Covers

Install the side covers for battery control unit and battery module and secure it with screws (M4*25).

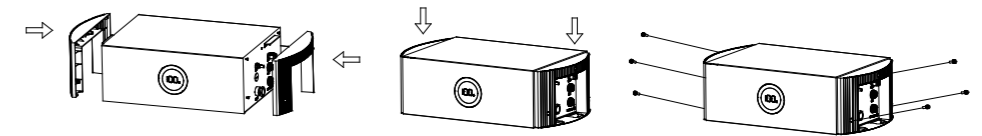

Figure 5.7
Installing side covers for
battery control unit

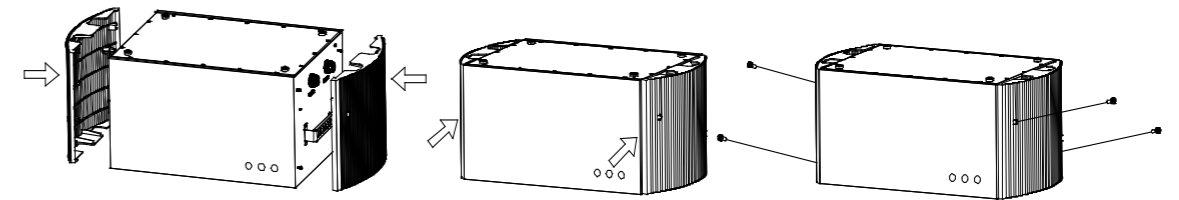

Figure 5.8
Installing side covers for
battery module

6.

COMMISSIONING



6.1 Start Up and Shut Down the Battery

6.1.1 Start Up

Step 1: Turn on the circuit breaker

Step 2: Press and hold the main switch for 2-3s, until the display is on

6.1.2 Shut Down

Step 1: Press and hold the main switch for 5s, until the display is off

Step 2: Turn off the circuit breaker

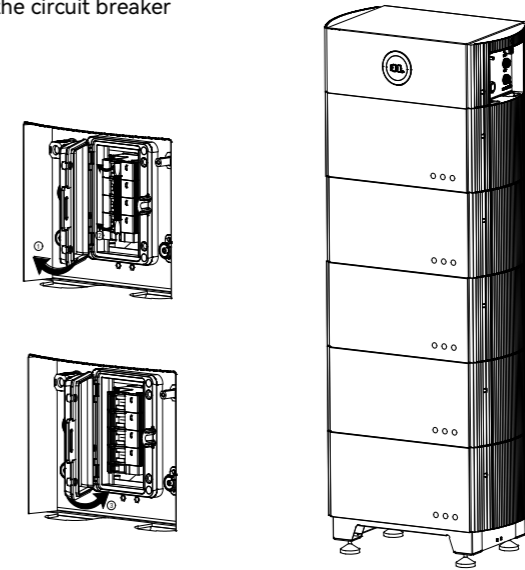

Figure 6.1
Circuit breaker of battery

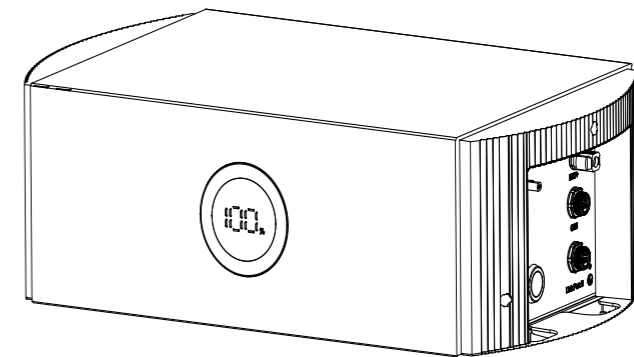

Figure 6.2
Main switch of battery

6.2 Introduction of Human-computer Interface

System commissioning

After the wiring is completed, please refer to the inverter manual for system commission and operation.

Note: Turn on the circuit breaker and main switch when using the B2 battery.

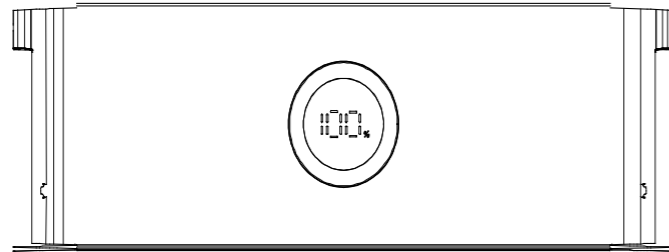





Figure 6.3
Human-computer interface

Display	Status	Description
Ring Light		Solid Green The battery is in normal state
		Breathing Mode The battery is in the initialization or waiting state
		Solid Red An error occurs
		Breathing Mode Software is upgrading in the battery
		OFF Power off
LED Panel 1		SOC of the battery

Note: One breathing cycle is 6 seconds

Table 6.1
Interface description

6.3 Commissioning

Please refer to inverter manual for eSolar APP download and system commissioning. Please select SAJ for battery brand.



Figure 6.4
Selecting the battery brand interface

7.

BATTERY MAINTENANCE



7.1 Transportation

Lithium batteries are dangerous goods. Passed the test of UN38.3, this product meets the transportation requirements for dangerous goods for lithium batteries. After the installation of the battery on site, the original packaging (contains the lithium battery identification) should be kept. When the battery needs to be returned to the factory for repair, please pack the battery with the original packaging to reduce unnecessary trouble.

7.2 Storage

After purchasing the battery, please store it with following instructions:

- 1) Please store it in a dry and ventilated environment, keep it away from heat sources;
- 2) Please keep it in an environment with storage temperature as $-20^{\circ}\text{C} \sim 40^{\circ}\text{C}$, humidity $<85\%$ RH (applicable to storage months <3);
- 3) For long-term storage ($3 < \text{months} < 6$), please put it in an environment with a temperature of -20°C to 25°C and a humidity of $<85\%$ RH;
- 4) The battery should be stored in accordance with the storage requirements mentioned above, and the battery should be installed within 6 months since delivered from the factory and used with compatible inverters;
- 5) If stored for more than 6 months under the specified conditions, the battery needs to be charged once, until the system SOC is 50% to 80%. Preferably, use an inverter for forced charging.

NOTICE

- The battery remains 50% power when it is sent from the factory.
- The longer the battery is stored, lower the SOC. When the battery remaining voltage fails to reach the startup voltage requirement, the battery may be damaged.
- Judgment condition: Close the battery breaker switch and press the main switch. At this time, if the LED light is solid green, it is running normal. If the LED light is red or off, the battery is in fault.

The battery cannot be disposed of as household refuse. When the service life of the battery reaches to the limit, it is not required to return it to the dealer or SAJ, but it must be recycled to the special waste lithium battery recycling station in the area.

7.3 Maintenance

Below is the recommended maintenance cycle. The actual maintenance cycle can be adjusted according to the specific installation environment of this product.

The power station scale, installation location and on-site environment will affect the maintenance cycle of this product. In sandy or dusty environments, it is necessary to shorten the maintenance cycle and increase the frequency of maintenance.

Maintenance performed once a year:

■ Battery module status

Check the following items. Take corrective actions immediately for any abnormal situations:

- Check the battery module and internal devices for damage or deformation.
- Check the internal devices for abnormal noise during operation.
- Check whether the temperature inside the battery cluster is too high.
- Check whether the internal humidity and dust of the battery module are within the normal ranges. If necessary, clean the battery module.

■ Warning symbols

Ensure the warning symbols and label are legible. If necessary, clean them.

■ Wire and cable

Ensure the switch gear and PCS are connected correctly.

■ Corrosion

Check the battery module for internal oxidation or rust.

Maintenance performed once every six months:

■ Switch gear and battery module

Check the following items. In case of nonconformity, take corrective actions immediately:

- Check whether there are flammable objects around the battery module.
- Check whether the battery module is reliably fixed on the wall, and whether any fixing point is corroded.
- Check the switch gear and battery module for damage, paint peeling, oxidation, etc.

■ Wire and cable layout

Before any operation, ensure all internal devices of the battery module are powered off.

In case of nonconformity found in inspection, take corrective actions immediately:

- Check the cable layout for short circuit and compliance with the specifications. In case of any abnormality, take corrective actions immediately.
- Check the battery module for internal seepage of water.
- Check whether the cables are loose, and tighten them according to the aforesaid torque.

■ Grounding

Ensure the grounding is correct.

■ Function inspection

Ensure the current, voltage and temperature in the operation record of the battery module are within the operating ranges.

Troubleshooting

Code	Error Name	Common Cause	Remedy
97	BMS internal communication error	<ol style="list-style-type: none"> 1. Communication error between battery control unit and battery module 2. Did not install RJ45 plug, therefore battery control unit counted the number of battery modules connected mistakenly 	<ol style="list-style-type: none"> 1. Check if communication cable is connected properly 2. Check if RJ45 plug is installed
98	Battery module sequence error	<ol style="list-style-type: none"> 1. Cable connection is wrong 2. Did not install RJ45 plug 3. Communication cable connection is wrong 	<ol style="list-style-type: none"> 1. Connect the cable correctly 2. Check if the RJ45 plug is installed 3. Check if the communication cable is working
99	Discharge overcurrent protection	Discharging current exceeds the set limit	Wait until the error is clear or restart
100	Charge overcurrent protection	Charging current exceeds the set limit	Wait until the error is clear or restart
101	Total voltage low protection	Total voltage is lower than the set limit	Force charging the battery
102	Total voltage high protection	Total voltage is higher than the set limit	Wait until the error is clear or restart
103	Single battery module voltage low protection	Single battery module voltage is lower than the set limit	Force charging the battery
104	Single battery module voltage high protection	Single battery module voltage is higher than the set limit	Wait until the error is clear or restart
105	BMS hardware error	<ol style="list-style-type: none"> 1. Single battery module voltage sensor error 2. Temperature sensor error 3. Current sensor error 	<ol style="list-style-type: none"> 1. Check if battery temperature and voltage sensor cable is in poor contact 2. Check if current sensor cable is in poor contact 3. Replace BMS
106	Charging temperature low protection	Battery charging at <math><0^{\circ}\text{C}</math>	Wait until battery temperature increased and the error is clear

TROUBLESHOOTING & WARRANTY



Code	Error Name	Common Cause	Remedy
107	Charging temperature high protection	Battery temperature too high	Wait until battery temperature decreased and the error is clear
108	Discharging temperature low protection	Battery temperature too low, disconnect relay to stop discharging	Wait until battery temperature increased and the error is clear
109	Discharging temperature high protection	Battery temperature too high	Wait until battery temperature decreased and the error is clear
110	Relay error	1. Cathode or anode relay is adhesive 2. Cathode or anode relay is unable to close	Replace relay
111	Pre-charge error	1. Pre-charge relay damaged 2. Pre-charge resistor open-circuit 3. BMS damaged	1. Replace pre-charge relay 2. Replace pre-charge resistor 3. Replace BMS
112	Insulation error	Battery module has electricity leakage	Contact battery supplier
113	BMS supplier incompatibility	BMS of battery module and battery control unit are incompatible	Check if the model of battery module and battery control unit are compatible
114	Battery cell supplier impartibility	Supplier of battery module and battery cell are incompatible	Check if the model of battery module is correct
115	Battery cell incompatibility	Battery cells are incompatible	Check if the model of battery module is correct
116	Voltage inconsistency	Battery module voltage are inconsistent	Check if the model of battery module is correct
117	Circuit breaker is open	1. Circuit breaker is open 2. Circuit breaker auxiliary contact error	Replace circuit breaker
118	Temperature difference is too wide	1. Temperature sensor error 2. Battery life span	1. Check if temperature sensor cable is in poor contact
119	Voltage difference is too wide(Class II)	1. Sensor cable is loose 2. Battery life span	1. Check if voltage sensor cable is in poor contact 2. Replace BMS

Code	Error Name	Common Cause	Remedy
120	Voltage difference is too wide (Class I)	1. Sensor cable is loose	1. Check if voltage sensor cable is in poor contact 2. Replace BMS
121	BMS over temperature protect	1. Ambient temperature is high 2. Overload	1. Check if ambient temperature is high 2. Check if overloaded
122	Short circuit protect	P+ and P- short circuit	Check if the cable connected correctly

Warranty

Please go to SAJ website for warranty conditions and terms
<https://www.saj-electric.com/>